



# MDX-E300

*Minidisc Recorder*

*Lecteur Enregistreur de Minidisc*



**MDLP**



micro component system

**PIANOCRAFT**

**OWNER'S MANUAL  
MODE D'EMPLOI  
BEDIENUNGSANLEITUNG  
BRUKSANVISNING  
MANUALE DI ISTRUZIONI  
MANUAL DE INSTRUCCIONES  
GEBRUIKSAANWIJZING**

## CAUTION: READ THIS BEFORE OPERATING THIS UNIT

- 1 To assure the finest performance, please read this manual carefully. Keep it in a safe place for future reference.
- 2 Install this unit in a well ventilated, cool, dry, clean place away from direct sunlight, heat sources, vibration, dust, moisture or cold. In a cabinet, allow about 2.5 cm (1 inch) of free space all around this unit for adequate ventilation.
- 3 Locate this unit away from other electrical appliances, motors, or transformers to avoid humming sounds.
- 4 Do not expose this unit to sudden temperature changes from cold to hot, nor locate this unit in an environment with high humidity (i.e., a room with a humidifier) to prevent condensation inside this unit, which may cause an electrical shock, fire, damage to this unit, and/or personal injury.
- 5 Avoid installing this unit in a location where foreign objects may fall onto this unit or where this unit may be exposed to liquid dripping or splashing. On the top of this unit, do not place:
  - Other components, as they may cause damage and/or discoloration on the surface of this unit.
  - Burning objects (i.e., candles), as they may cause fire, damage to this unit, and/or personal injury.
  - Containers with liquid in them, as they may fall, spilling the liquid and causing an electrical shock to the user and/or damage to this unit.
- 6 Do not cover this unit with a newspaper, tablecloth, curtain, etc. in order not to obstruct heat radiation. If the temperature inside this unit rises, it may cause fire, damage to this unit, and/or personal injury.
- 7 Do not plug in this unit to a wall outlet until all connections are complete.
- 8 Do not operate this unit upside-down. It may overheat, possibly causing damage.
- 9 Do not use excessive force on switches, knobs and/or cords.
- 10 When disconnecting the power cord from the wall outlet, grasp the plug; do not pull the cord.
- 11 Do not clean this unit with chemical solvents; this might damage the finish. Use a clean, dry cloth.
- 12 Use only the voltage specified on this unit. Using this unit with a higher voltage than specified is dangerous and may cause fire, damage to this unit, and/or personal injury. YAMAHA will not be held responsible for any damage resulting from use of this unit with a voltage other than as specified.
- 13 To prevent damage by lightning, disconnect the power cord from the wall outlet during an electrical storm.
- 14 Do not attempt to modify or fix this unit. Contact qualified YAMAHA service personnel when any service is needed. The cabinet should never be opened for any reason.
- 15 When not planning to use this unit for long periods of time (i.e., vacation), disconnect the AC power plug from the wall outlet.
- 16 Be sure to read the "Troubleshooting" section on common operating errors before concluding that this unit is faulty.
- 17 Before moving this unit, press STANDBY/ON to set the unit in standby mode, then disconnect the AC power plug from the wall outlet.
- 18 **VOLTAGE SELECTOR** (China and General models only)

The VOLTAGE SELECTOR on the rear panel of this unit must be set for your local main voltage BEFORE plugging into the AC main supply. Voltages are 110/120/220/240 V AC, 50/60 Hz.

To reduce the risk of fire or electric shock, do not expose this appliance to rain or moisture.

The unit is not disconnected from the AC power source as long as it is connected to the wall outlet, even if this unit itself is turned off. This state is called the standby mode. In this state, this unit is designed to consume a very small quantity of power.

### SPECIAL INSTRUCTIONS FOR U.K. MODEL

#### IMPORTANT:

The wires in the mains lead are coloured in accordance with the following code:

Blue: NEUTRAL

Brown: LIVE

As the colours of the wires in the mains lead of this apparatus may not correspond with the coloured markings identifying the terminals in your plug, proceed as follows: The wire which is coloured BLUE must be connected to the terminal which is marked with the letter N or coloured BLACK. The wire which is coloured BROWN must be connected to the terminal which is marked with the letter L or coloured RED. Making sure that neither core is connected to the earth terminal of the three pin plug.

#### For U.K. customers

If the socket outlets in the home are not suitable for the plug supplied with this appliance, it should be cut off and an appropriate 3 pin plug fitted. For details, refer to the instructions described above.

**Note:** The plug severed from the mains lead must be destroyed, as a plug with bared flexible cord is hazardous if engaged in a live socket outlet.

#### CAUTION

Use of controls or adjustments or performance of procedures other than those specified herein may result in hazardous radiation exposure.

## FEATURES

- MINI DISC digital audio system
- Digital optical input (2)/output
- Sampling rate converter
- EDIT function
- Synchronized recording/timer recording by system connection
- Digital rec level control
- MDLP (Long play and recording)

## CONTENTS

### **FEATURES ..... 1**

### **SUPPLIED ACCESSORIES ..... 2**

### **NOTES ABOUT MINIDISCS ..... 2**

### **NAMES OF BUTTONS AND CONTROLS**

Front panel .....	3
Display .....	3
Remote control .....	4

### **GETTING STARTED**

Remote control .....	5
System connections .....	6
Connecting your audio system .....	8

### **PLAYBACK ..... 9**

Skipping tracks .....	9
Searching .....	9
Switching the display .....	10
Random play .....	11
Repeat play .....	11
A-B repeat .....	11
Program play .....	12

### **RECORDING ..... 13**

Adjusting recording levels .....	14
Track marking .....	14
Music synchro recording .....	15
Setting the recording mode .....	15
Monitor out .....	16
Protecting a recorded MD .....	16

### **EDITING ..... 17**

Erase .....	18
Move .....	19
Combine .....	19
Divide .....	20
Undo .....	20
TOC write .....	20
FRA check .....	20

### **TITLING ..... 21**

### **ADDITIONAL INFORMATION**

MD recorder system notes .....	22
Display messages .....	23
Troubleshooting .....	24
Specifications .....	25

## SUPPLIED ACCESSORIES

Check that the following items are included.

- Remote control

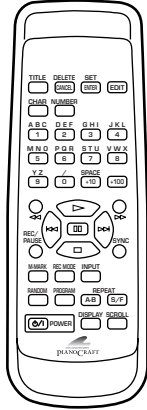

- Optical cable

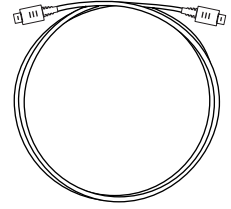

- System control cable

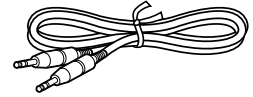

- Batteries (AA, R6, UM-3)

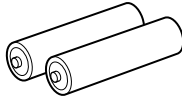

- Audio pin cable

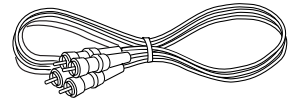

## NOTES ABOUT MINIDISCS

### Care of MDs

- Do not expose the MD to direct sunlight or heat sources such as hot air ducts, nor leave it in a car parked in direct sunlight as there can be a considerable rise in temperature inside the car.
- Periodically remove dust and debris from the cartridge surface by wiping it with a dry cloth.
- Because the MD itself is housed in a cartridge, you can handle it normally without being concerned about dirt or fingerprints. However, malfunctioning may result if the cartridge itself is dirty or warped.

### Do not open the shutter on the MD cartridge

Trying to force the shutter open will damage the shutter.

## Front panel

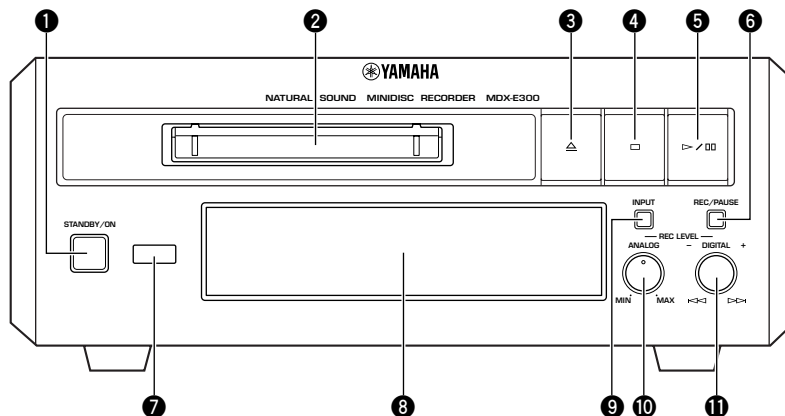

- ❶ **STANDBY/ON** (P.9)
- ❷ **Disc insertion slot** (P.9)
- ❸  $\triangle$  (P.9)
- ❹  $\square$  (P.9)
- ❺  $\triangleright/\square$  (P.9)
- ❻ **REC/PAUSE** (P.13)
- ❼ **Remote control sensor** (P.5)
- ❽ **Display** (P.3)
- ❾ **INPUT** (P.13)
- ❿ **ANALOG REC LEVEL** (P.14)
- ⓫ **Jog dial ( $\ll \ll \gg \gg$ )/DIGITAL REC LEVEL** (P.9/P.14)

## Display

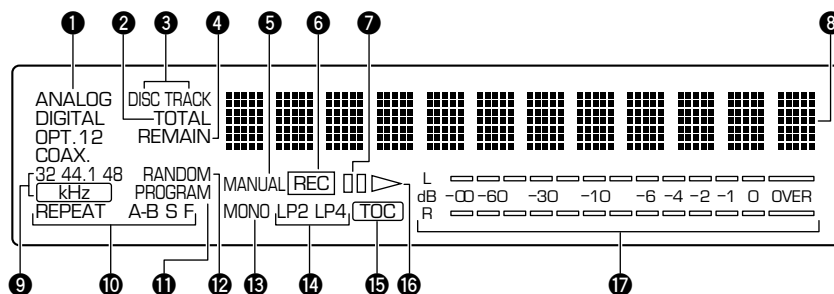

- ❶ **Input indicator** (P.13)
- ❷ **TOTAL** indicator (P.10)
- ❸ **DISC/TRACK** indicator (P.10)
- ❹ **REMAIN** indicator (P.10)
- ❺ **MANUAL** indicator (P.14)
- ❻ **REC** indicator (P.13)
- ❼ **Pause indicator**
- ❽ **Multi information display**
- ❾ **Sampling frequency indicator** (P.13)
- ❿ **REPEAT A-B/S F** indicator (P.11)
- ⓫ **PROGRAM** indicator (P.12)
- ⓬ **RANDOM** indicator (P.11)
- ⓭ **MONO** indicator (P.15)
- ⓮ **LP2/LP4** indicator (P.15)
- ⓯ **TOC** indicator (P.17)
- ⓰ **Play indicator**
- ⓱ **Recording level meter** (P.14)

## Remote control

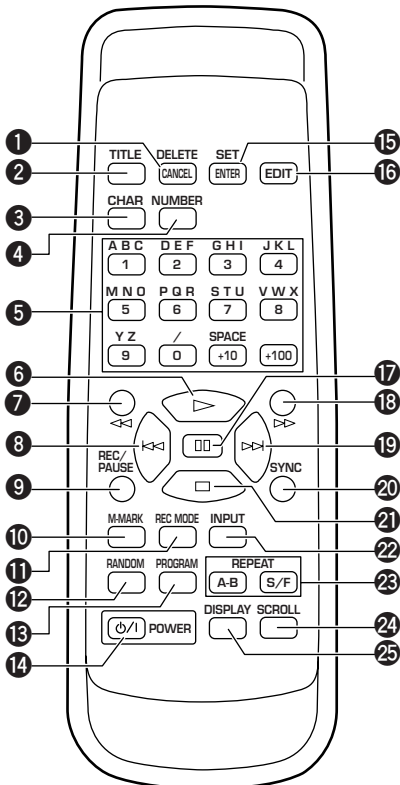

- ① DELETE/CANCEL (P.21)
- ② TITLE (P.21)
- ③ CHAR (P.21)
- ④ NUMBER (P.21)
- ⑤ Numbers [Characters] (P.9/P.21)
- ⑥ ▷ (P.9/P.14)
- ⑦ ◀◀ (P.9/P.21)
- ⑧ ◀◀◀ (P.9/P.21)
- ⑨ REC/PAUSE (P.13)
- ⑩ M-MARK (P.14)
- ⑪ REC MODE (P.15)
- ⑫ RANDOM (P.11)
- ⑬ PROGRAM (P.12)
- ⑭ POWER (P.9)
- ⑮ SET/ENTER (P.21)
- ⑯ EDIT (P.18)
- ⑰ ◻◻ (P.9)
- ⑱ ▷▷ (P.9/P.21)
- ⑲ ▷▷◀ (P.9/P.21)
- ⑳ SYNC (P.15)
- ㉑ ◻ (P.9)
- ㉒ INPUT (P.13)
- ㉓ REPEAT A-B (P.11)  
REPEAT S/F (P.11)
- ㉔ SCROLL (P.10)
- ㉕ DISPLAY (P.10)

## Remote control

### Battery installation

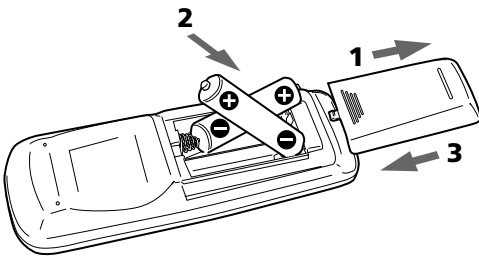

- 1** Remove the battery compartment cover.
- 2** Insert batteries into the battery compartment.
- 3** Replace the battery compartment cover.

### Battery replacement

If you find that the remote control must be used closer to the main unit than usual, the batteries are weak. Replace batteries with new ones.

#### Notes

- Use only AA, R6, UM-3 batteries for replacement.
- Be sure the polarities are correct. (See the illustration inside the battery compartment.)
- Remove the batteries if the remote control will not be used for an extended period of time.
- If batteries leak, dispose of them immediately. Avoid touching the leaked material or letting it come in contact with clothing, etc. Clean the battery compartment thoroughly before installing new batteries.

### Remote control operation range

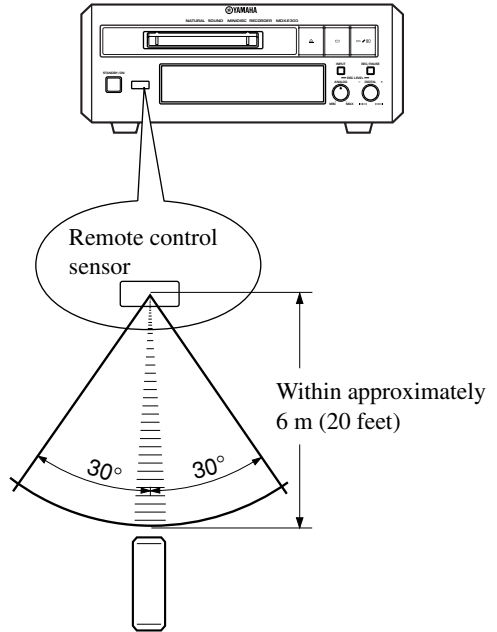

#### Notes

- There should be no large obstacles between the remote control and the main unit.
- If the remote control sensor is directly illuminated by strong lighting (especially an inverter type of fluorescent lamp, etc.), it might cause the remote control not to work correctly. In this case, reposition the main unit to avoid direct lighting.

### Removing the protection sheet

The remote control is shipped with a protection sheet to prevent the surface from being scratched during transportation.

When removing the sheet, first put adhesive tape on an edge of the remote control so that the tape sticks to the sheet. Then peel the sheet off with the tape.

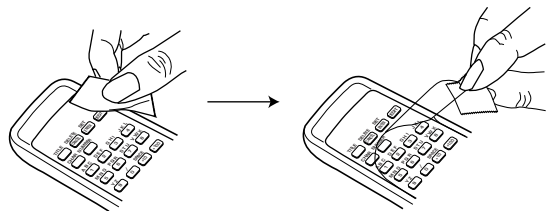

#### Note

- Do not scratch the remote control surface when peeling the sheet off.

## System connections

**Never plug the AC power cord to the wall outlet until all connections are completed.**

- Connections should be made to the correct input/output jacks on the other component.
- Also refer to the owner's manual supplied with the components you are connecting.
- If the placement of this unit causes noise in other equipment, such as a tuner, move them farther apart.
- The connection using the SYSTEM CONNECTOR jack allows you to control this unit as well as the connected components of YAMAHA Piano Craft series. Make system control connections between the Piano Craft series components using the system control cable.

To reduce the standby power consumption, connect the AC power cord of this unit to a switched AC outlet of your receiver (Except for U.K. model).

### Notes

- Before making OPTICAL connections, remove the jack cover(s).
- In order to protect the jacks from dust, be sure to attach the jack covers when the optical jacks are not being used.

### Connecting CRX-E300

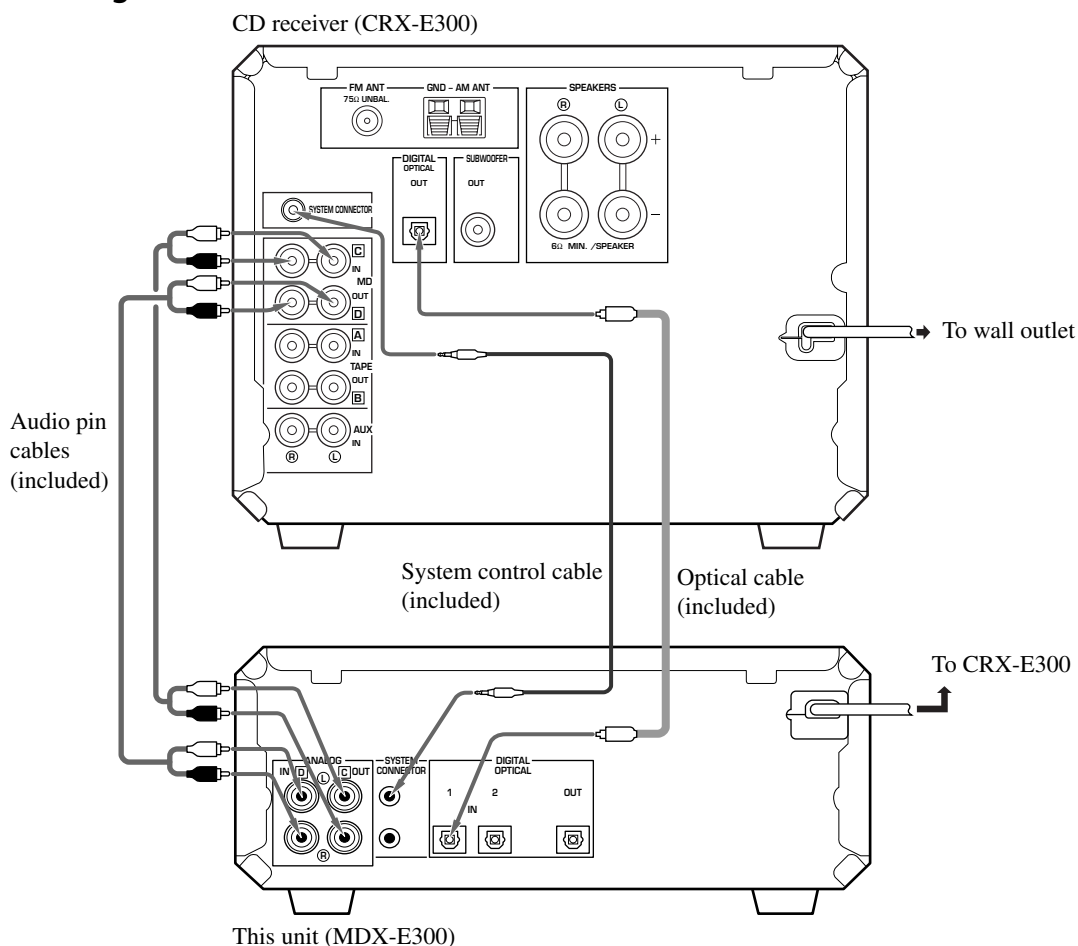

### Notes

- The ANALOG OUT jacks on this unit are marked [C] and the ANALOG IN jacks are marked [D]. When connecting this unit to CRX-E300 whose jacks are marked [A], [B], [C] and [D], connect this unit's ANALOG OUT jacks to the input jacks marked [C] and connect this unit's ANALOG IN jacks to the output jacks marked [D] on the rear panel of CRX-E300.
- The SYSTEM CONNECTOR jack should be connected to the SYSTEM CONNECTOR jack on CRX-E300.
- For digital recording, the DIGITAL OPTICAL 1 IN jack should be connected to the DIGITAL OPTICAL OUT jack on CRX-E300.



## Connecting RX-E400 and CDX-E400

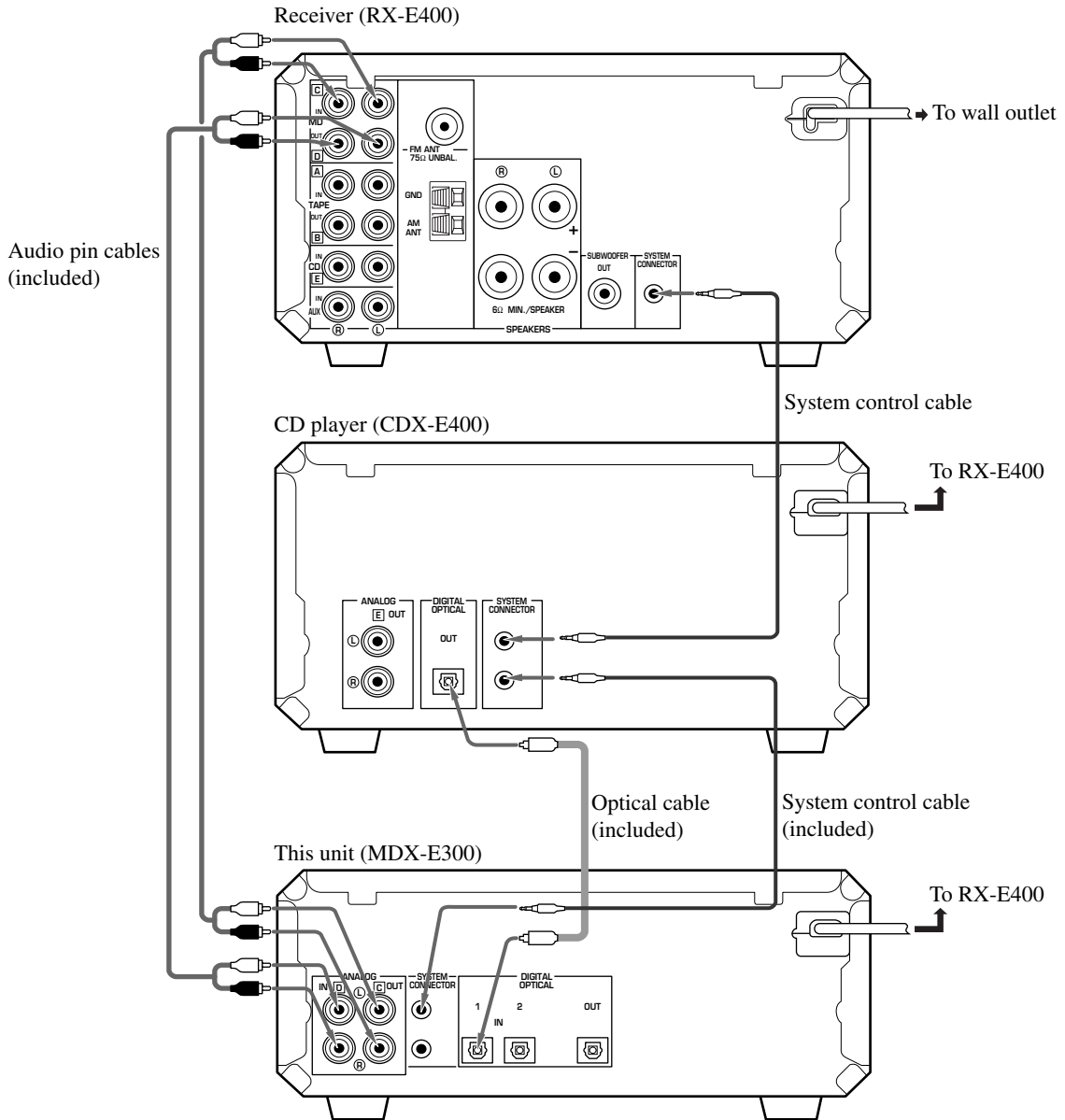

### Notes

- The ANALOG OUT jacks on this unit are marked [C] and the ANALOG IN jacks are marked [D]. When connecting this unit to RX-E400 whose jacks are marked [A], [B], [C], [D] and [E], connect this unit's ANALOG OUT jacks to the input jacks marked [C] and connect this unit's ANALOG IN jacks to the output jacks marked [D] on the rear panel of RX-E400.
- The SYSTEM CONNECTOR jack should be connected to the SYSTEM CONNECTOR jack on CDX-E400.
- For digital recording, the DIGITAL OPTICAL 1 IN jack should be connected to the DIGITAL OPTICAL OUT jack on CDX-E400.

## Connecting your audio system

### Digital connections

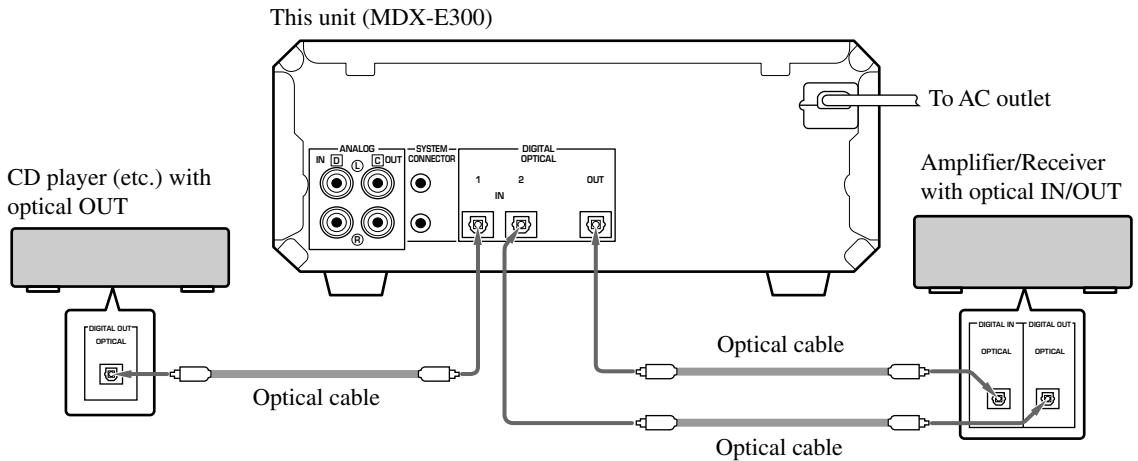

#### Notes for digital connections

- The DIGITAL OPTICAL IN jacks can be connected to any component with an optical output so you can make direct digital recordings.
- The DIGITAL OPTICAL OUT jacks can be connected to any component with an optical input so you can output digital audio from an MD.
- Before making OPTICAL connections, remove the jack cover(s).
- In order to protect the jacks from dust, be sure to attach the jack covers when the optical jacks are not being used.

### Analog connections

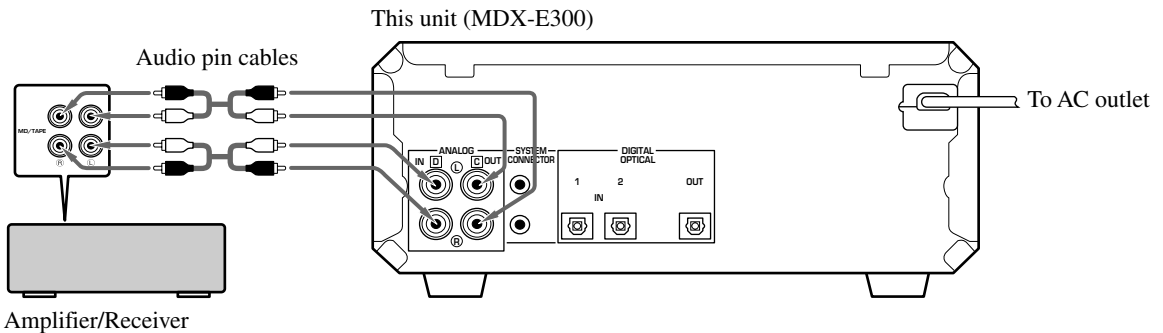

#### Notes for analog connections

- The white plug on the audio pin cables corresponds to the L (left) channel and the red plug corresponds to the R (right) channel. Be sure to connect L (left) to L and R (right) to R. Also make sure that the plugs are fully inserted and that the connection is firm.
- The ANALOG OUT jacks on this unit should be connected to the MD PLAY jacks on your amplifier.  
The ANALOG IN jacks on this unit should be connected to the MD REC jacks on your amplifier.

## Preparation

- Press **STANDBY/ON (POWER)** on the remote control to turn this unit on.
- Select “MD” as the input source of the connected receiver.

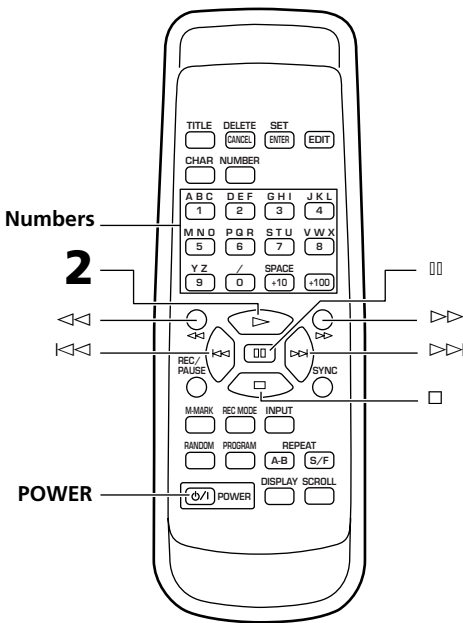
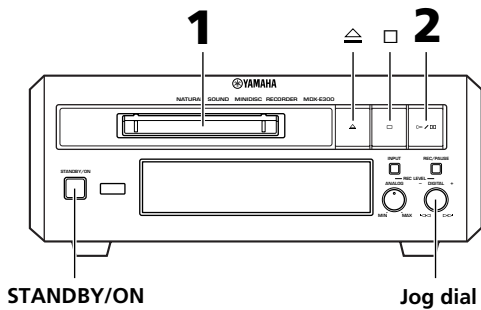

- 1 Insert an MD.

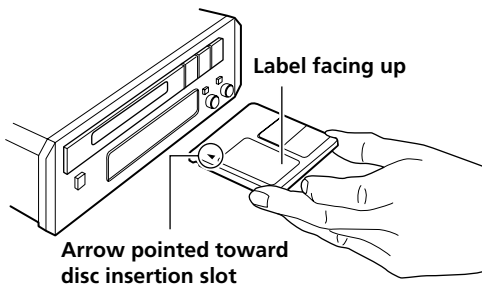

- 2 Press **▷/⏵** (▷ on the remote control) to start playback.
- 3 Adjust the volume using the volume control on the amplifier (or receiver).

## To pause

Press **▷/⏵** (⏵ on the remote control).  
Press again to resume playback (or press **▷** on the remote control).

## To stop

Press **□**.

## To eject the MD

Press **⏏**.

## Skipping tracks

### To skip to the next track

Turn the jog dial to the right (or press **▷▷** on the remote control).

### To skip to a previous track

Turn the jog dial to the left (or press **◁◁** on the remote control).

### To skip to a specific track number

Press the number buttons on the remote control corresponding to the track you desire.

#### Example:

- To select track 3, press **3**.
- To select track 13, press **+10**, then press **3**.
- To select track 23, press **+10** twice, then press **3**.
- To select track 123, press **+100** once, and **+10** twice, then press **3**.

## Searching

### To search forward during play or pause

Press and hold **▷▷** on the remote control.

### To search in reverse during play or pause

Press and hold **◁◁** on the remote control.

#### Notes

- Sound can be heard when searching in play mode to help you locate the desired position within the track. No sound is heard when searching in pause mode, but the search is conducted at a higher speed.
- Search may not function correctly when there are several consecutive tracks consisting of only a few seconds each.

## Switching the display

Press **DISPLAY** during stop or playback to display other information, such as the remaining time and track titles.

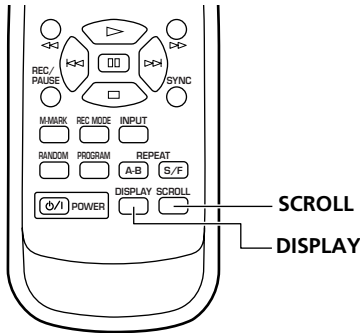

### During stop

Press **DISPLAY** repeatedly to display the following information.

- ① Number of tracks and total playing time

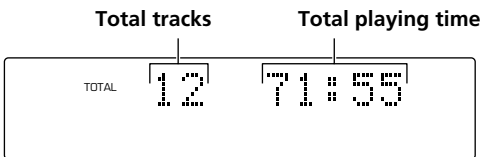

- ② Time remaining on the MD (only for recordable MDs)

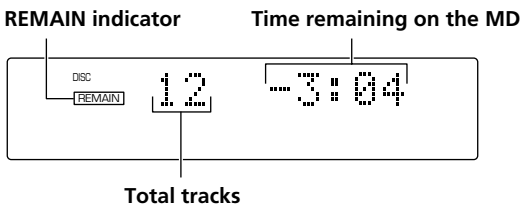

- ③ Disc title

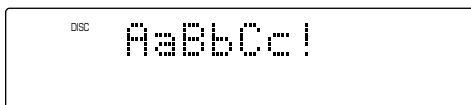

### During playback

Press **DISPLAY** repeatedly to display the following information.

- ① Current track number and elapsed time

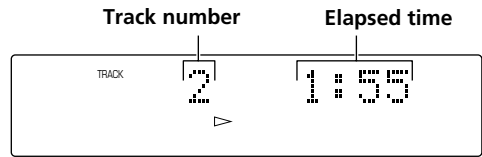

- ② Time remaining on the current track

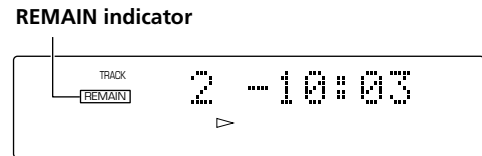

- ③ Track title

- If the track has not been given a name, "No Title" is displayed.

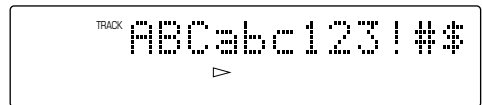

### To view the entire disc (track) title

If the disc (track) title is too long to fit in the display, press **SCROLL** to move the title sequentially across the display. While the title is being displayed, press **SCROLL** to pause the display, and again to continue presentation of the title. Press and hold **SCROLL** for rapid presentation of the title.

## Random play

You can have the unit play all the tracks on a disc in random order.

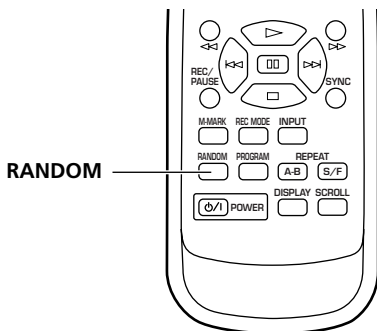

### To start random playback

Press **RANDOM**.

The **RANDOM** indicator lights up and “\_ \_ \_ \_ - - : - -” appears in the display while the unit selects a track. Playback starts automatically.

### To cancel

Press **RANDOM** again to turn off the **RANDOM** indicator or press  $\square$ .

#### Note

- Pressing  $\triangleright \triangleright$  during random play skips to another track at random. Pressing  $\triangleleft \triangleleft$  returns to the beginning of the current track (you cannot return to previously played tracks).

## Repeat play

You can have the unit repeat a single track, a full disc, or just part of a track.

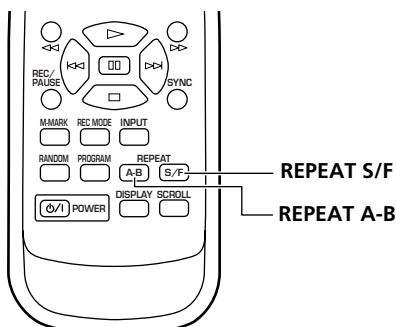

Press **REPEAT S/F** repeatedly to light the **REPEAT S** or **REPEAT F** indicators.

To repeat the single track, light the **REPEAT S** indicators.



To repeat the full disc, light the **REPEAT F** indicators.



### To cancel

Press **REPEAT S/F** repeatedly to turn off the **REPEAT S** or **REPEAT F** indicators.

#### Notes on full disc repeat

- In program play mode, the entire program is played repeatedly.
- In random play mode, the unit reshuffles the tracks and plays them again after each track plays once.

## A-B repeat

This function lets you repeat a specific part of a track. It's a convenient way to study a language, or to learn the lyrics to your favorite song (etc.).

- Press **REPEAT A-B** during playback to specify the beginning (A point) of the part you want to repeat.
  - The **REPEAT A** indicators light up.



- Press **REPEAT A-B** again to specify the end (B point) of the part you want to repeat.
  - The **REPEAT A-B** indicators light up and the part you specified starts to repeat.

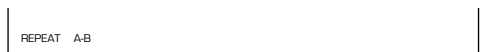

### To cancel

Press  $\square$  or **REPEAT A-B**.

## Program play

This function lets you enjoy listening to your favorite tracks in any order you desire.

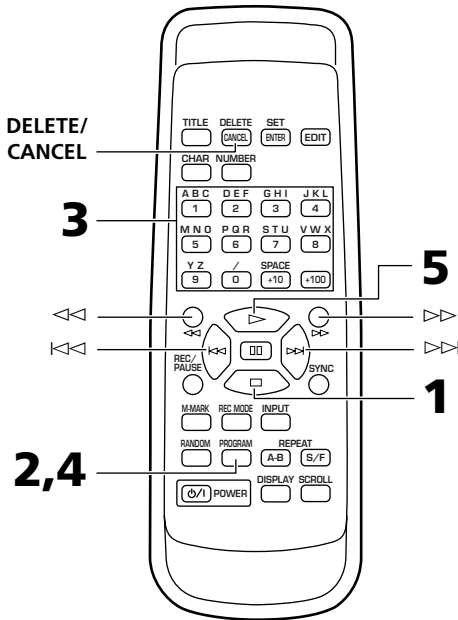

- 1** Press  to stop playback.
- 2** Press **PROGRAM** to light up the PROGRAM indicator.
- 3** Program the desired track by pressing the corresponding number buttons.

### Example:

To select track 3, press **3**.  
 To select track 13, press **+10**, then press **3**.  
 To select track 23, press **+10** twice, then press **3**.  
 To select track 123, press **+100** once, and **+10** twice, then press **3**.

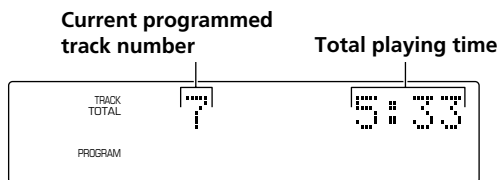

Repeat this operation to program up to 30 steps.

- 4** Press **PROGRAM** to confirm the program.
- 5** Press **>** to start program playback.

## To check the programmed data

- ① Stop or pause program playback.
- ② Press **<<** or **>>** to skip through the step information (or use the jog dial on the front panel).

## To change a step

- ① Stop program playback.
- ② Press **PROGRAM**.
- ③ Press **<<** or **>>** to skip through the step information (or use the jog dial on the front panel).
- ④ Use the number buttons to program a new track number for that step. The original track is cleared from memory and the new track is programmed.

## To delete a specific step

- ① Stop program playback.
- ② Press **PROGRAM**.
- ③ Press **<<** or **>>** to skip through the step information (or use the jog dial on the front panel).
- ④ Press **DELETE** to delete the step. The higher steps are renumbered automatically.

## To cancel

During the stop mode, press  to turn off the PROGRAM indicator.

### Notes

- If the total time exceeds 100 minutes, "Over" is displayed instead of the total time.
- **<<** or **>>** can be used during playback to skip between programmed tracks.

## Note

Please check the copyright laws in your country to record from records, compact discs, radio, etc. Recording of copyright material may infringe copyright laws.

This unit allows you to make recordings from a wide variety of program sources (both analog and digital). When recording an analog source (such as an FM broadcast or cassette) this unit converts the analog signals to a 44.1 kHz digital signal before recording them onto the MD.

When recording a digital source, this unit converts the digital signals to 44.1 kHz for recording onto the MD. However, if you are recording a 44.1 kHz source signal (such as a CD) there is no conversion. This unit can record 32, 44.1 and 48 kHz digital signals.

## Preparation

- Press **STANDBY/ON (POWER)** on the remote control to turn this unit on.

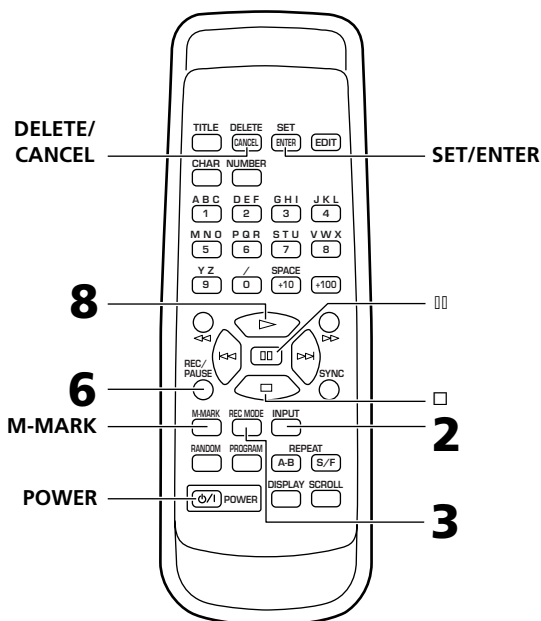
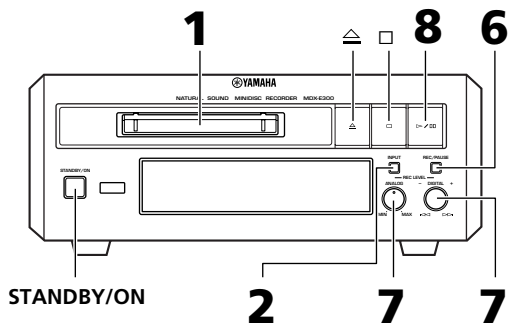

- 1 Insert an MD.

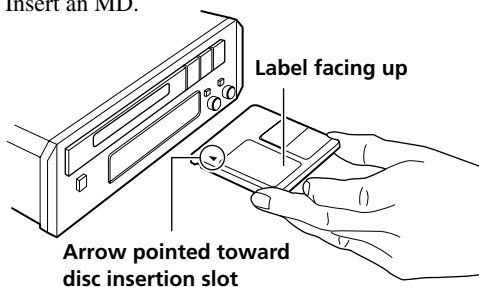

- 2 Press **INPUT** repeatedly to select the input you want to record.

For	Select
ANALOG IN <input type="checkbox"/>	ANALOG
DIGITAL OPTICAL 1 IN <input type="checkbox"/>	DIGITAL OPT. 1
DIGITAL OPTICAL 2 IN <input type="checkbox"/>	DIGITAL OPT. 2

### Input indicator

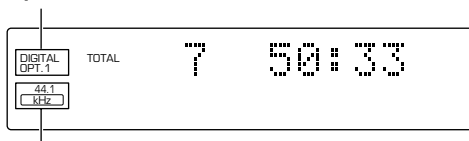

### (Source) sampling frequency indicators\*

- \* Appears when digital signal is input.

- 3 If desired, press **REC MODE** to select the recording mode (see "Setting the recording mode" on page 15).
- 4 Locate the point where you want to start recording.

### When recording on a blank MD

- Skip this step.

### To start recording from the end of a previous recording

- Press  to set this unit to stop mode.

### To record over a previous recording

- Turn the jog dial (or press  or  on the remote control) to select a track (recording starts from the beginning of the deleted track).

- 5 Start playing the source to be recorded.

- If you do not need to adjust the recording level, this step is not necessary.

- 6 Press **REC/PAUSE** to set this unit to record pause mode.

- The REC  indicators light up. "REC Standby" and the amount of time available for recording flash alternately in the display.

### If you selected a track number (in step 4) to record over a previous recording

- "OverWrite OK?" appears in the display. To confirm, press **SET/ENTER**. This operation will erase the selected track number (or point) and all subsequent material. To cancel, press **DELETE/CANCEL** (or ).

- 7** Adjust the recording levels. (See “Adjusting recording levels” on this page.)
- Before proceeding to the next step, be sure to reset the source to be recorded to the beginning.

- 8** Press ▷/⏏ (▷ on the remote control) to start recording.
- The TOC indicator lights up.  
When the TOC indicator is lit, this means that the TOC information has not yet been written to the disc. After recording is complete, the TOC data is automatically written to the disc.

- 9** Start playing the source to be recorded.
- Synchronized start is possible if you make system control connections to CRX-E300, CDX-E400 or KX-E300. Press ▷/⏏ on CRX-E300, CDX-E400 or ▷ on KX-E300 to start playing the source after step 7. The recording begins automatically. To use timer recording, please refer to the instructions supplied with CRX-E300 or CRX-E400.

## To pause

Press **REC/PAUSE**.

Press ▷/⏏ (▷ on the remote) to resume recording.

## To stop

Press □.

## To eject the MD

Press △.

If the power cord is disconnected while making a recording, the TOC data cannot be correctly written to the disc and the recorded data will be erased. TOC writing may be impossible (or track number marking may not perform as expected) when recording a damaged CD or a broadcast source with interference.

## Adjusting recording levels

### Setting the digital recording level

The digital recording level is set by default to 0 dB, the level of the input source. Normally, it is not necessary to adjust this level. However, because of the variance in levels between different digital formats and sources, it is possible to adjust the recording level of the digital signal. The digital level can be adjusted up to +12 dB and down to a minimum (MIN) level. Adjust **DIGITAL REC LEVEL** so that the highest peak causes the 0 dB level indicators to flicker. Do not cause the OVER indicator to light. Once recording is stopped, the digital recording level returns to the default level of 0 dB.

### Setting the analog recording level

For best results, play the loudest passage of the source to be recorded and watch the recording level meter in the display.

Adjust **ANALOG REC LEVEL** so that the highest peak causes the 0 dB level indicators to flicker. Do not cause the OVER indicator to light as it may produce distortion in the audio signal.

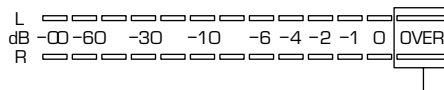

Should not light

#### Note

- To adjust the recording level of a source connected with the system control cable, remove the MD before pressing ▷/⏏ (or ▷) on the source component. If you press the button with an MD in this unit, the recording begins automatically.

## Track marking

When making a recording, you can choose either automatic or manual marking. This feature operates somewhat differently for analog and digital signals. See below for details.

Press **M-MARK** repeatedly to select automatic (MANUAL indicator is not lit) or manual (MANUAL indicator lit) marking.

### When recording analog signals

**Auto** : Track numbers are written in synchronization with the input level of the signal being recorded. During recording, if no sound is detected for more than 1.5 seconds, the recorder interprets this to be a gap between two tracks. When the source signal is detected again, a track number is automatically written.

**Manual** : One track number is written automatically when you start recording, but none are written during recording. To mark a track number, press **M-MARK** at the desired position while recording.

#### Note

- When using manual marking, the marks must be set at least 4 seconds apart.

### When recording digital signals

Track numbers are written in the same positions as the original source (CD, etc.) with either automatic or manual marking.

To add additional track numbers, set **M-MARK** to MANUAL and press **M-MARK** at the desired position while recording.

#### Notes

- When recording is paused, the portion recorded up to the pause is counted as an individual track. When recording is resumed, a new track number is created.
- During synchronized recording, manual track marking is not possible.



## Music synchro recording

The synchronized recording function lets you set this unit to start recording automatically when a sound signal is input.

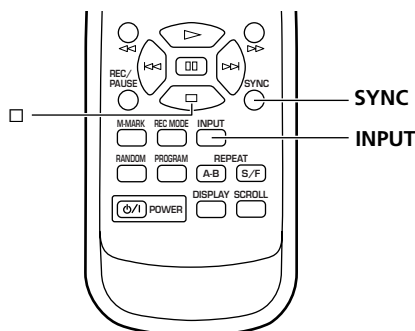

- 1** Load the sound source into the source component.
  - If necessary, program, or select the track you want to start recording from before proceeding to the next step. (Refer to the operation manual supplied with the source component for instructions regarding its use.)

- 2** Press **INPUT** repeatedly to select the input connected to the sound source you want to record.

- 3** Press **SYNC** to set this unit to record pause mode.
  - The REC  $\square\square$  indicators light up. “Synchro REC” and the amount of time available for recording flash alternately in the display. During synchronized recording, analog input sources are recorded at the current **ANALOG REC LEVEL** setting, digital sources are recorded at the 0 dB level.

The MD starts recording automatically when a sound signal is input. When the sound signal stops, the unit switches back to record pause mode and “Synchro REC” blinks in the display. The next time a sound signal is detected, recording starts again. In this manner, the presence of a sound signal automatically switches the unit between record and record pause modes.

- 4** Start playing the sound source.

## To cancel the synchronized recording mode

Press  $\square$ .

### Note

- When the signals at the beginning of a track are lower than the level required to start synchronized recording, they are not recorded. Should this occur, perform manual recording.

## Setting the recording mode

This unit incorporates various recording modes. Choose the one that suits your needs.

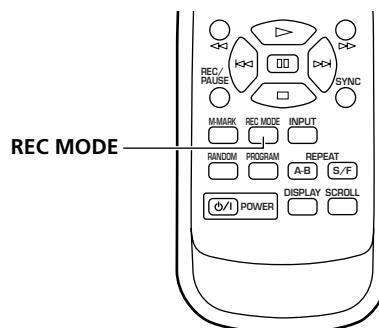

Press **REC MODE** repeatedly until the indicator for the desired recording mode lights up.

### Example: When using an 80 minute MD MONO (monaural)

This mode provides 160 minutes monaural recording.

### LP2

This mode provides 160 minutes stereo recording.

### LP4

This mode provides 320 minutes stereo recording.

When all of the above indicators are turned off, this unit enters normal stereo recording mode.

### Notes

- MDLPs (= discs recorded in LP mode) cannot be played back nor edited on non MDLP players. If you play MDLPs (=discs recorded in LP mode) on a non-MDLP player, “LP:” will appear at the top of the title and no sound will be reproduced.
- Normal stereo recording provides the best sound quality.
- The recording mode cannot be changed during recording.

## Monitor out

When a disc is not loaded, you can use the monitor out function to monitor the sound of the input source. The monitor out function can also be used to set recording levels without loading a disc.

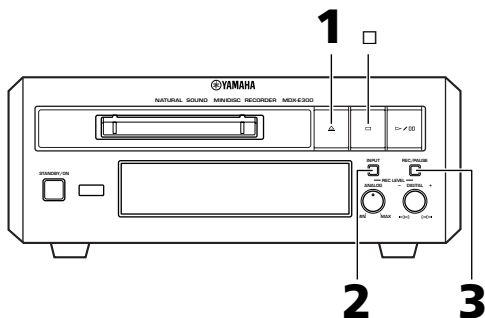

- 1** Press to remove the disc.
- 2** Press **INPUT** repeatedly to select the input connected to the sound source you want to monitor.
- 3** Press **REC/PAUSE**.
  - “Monitor Out” appears in the display.
  - Sound from the selected input will be output from this unit’s analog and digital output terminals.
- 4** Start playing the sound source.
  - The sound is output from the MD recorder’s analog and digital output terminals.

### To cancel

Press .

### Notes

- This function is useful to monitor the sound of an external digital component connected to the DIGITAL OPTICAL 2 IN jack.
- The digital volume can be adjusted when using the monitor out function. However, please note that the digital volume setting is restored to the default (0 dB) the next time a recording is made.

## Protecting a recorded MD

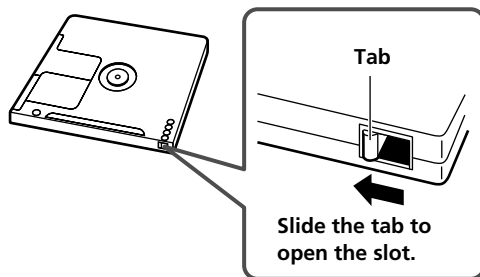

- To protect a recorded MD, slide the tab on the side of the MD to open the slot. In this position, the MD cannot be used for recording, editing, or titling. To record, edit, or title the MD, slide the tab to close the slot.
- If the MD is protected against erasure, “Protected” appears in the display.

One of the main advantages of MD is its editing capabilities. You can remove the commercials from a radio broadcast, reorder songs into the order you want, remove songs, combine songs, and even remove part of a song.

This unit offers the following editing operations.

## Erase

Lets you erase a track, the entire disc, or part of a track. You can also erase the title of a disc, or the titles of tracks on a disc.

## Move

Lets you move a track to a different track number.

## Combine

Lets you combine two adjacent tracks.

## Divide

Lets you split a single track into two different tracks.

## FRA check

Lets you recover disc space that may have been lost after multiple edit operations.

## TOC write

Lets you write TOC information to the disc so that changes are saved.

## Undo

Lets you undo the previous edit operation if you make a mistake.

## Notes on editing

### To cancel an edit

Press □.

### Before editing

Make sure that the MD is not protected against erasure. If the MD is protected, you cannot edit the MD. Slide the tab to close the slot on the side of the MD.

### After editing

- Press  $\triangle$  in order to update the TOC information and pull the MD out.
- The TOC indicator lights to show that the TOC information has not yet been written to the disc. Undo is possible only when the TOC indicator is lit.

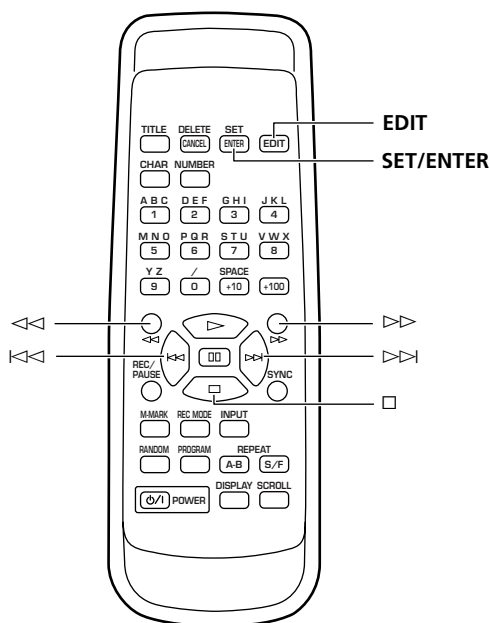

## Erase

The ability to erase sound without having to re-record is a convenient function of MD. You can erase the entire disc, a single track, or just part of a track.

### Disc erase

This operation lets you erase all audio and title (character) data to create a blank MD. Please note that once erased, this data can be recovered using the UNDO function.

- 1** Press  $\square$  to set this unit to stop mode.
- 2** Press **EDIT** repeatedly to display “Disc Erase?”, then press **SET/ENTER**.
  - “DiscEraseOK?” appears in the display.
- 3** Press **SET/ENTER** again.
  - When all audio, name and title data has been erased “Complete” appears momentarily.

### Track erase

This operation lets you erase a single track as well as corresponding title data. After you erase the track, the total number of tracks decreases by one and all tracks following that track are renumbered.

#### Example: Erasing track 3

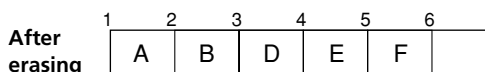
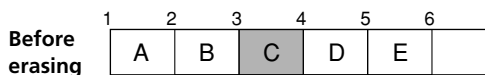

- 1** Use  $\lll$  or  $\ggg$  to select the track you want to erase.
- 2** Press **EDIT** repeatedly to display “Erase ?”, then press **SET/ENTER**.
  - “(track number) Erase OK?” appears in the display.
- 3** Press **SET/ENTER** again.
  - The track is erased and “Complete” appears momentarily.

#### If you plan to erase two or more tracks

To avoid confusion you should always erase from higher track numbers to lower track numbers. This prevents accidental renumbering of tracks you plan to erase.

### Part erase

This operation lets you erase part of a track.

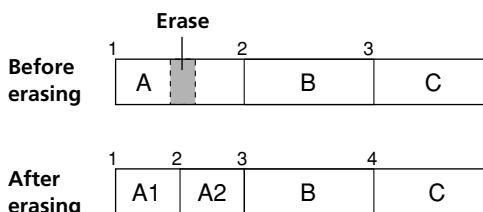

- 1** Play the track containing the part you want to erase.
- 2** Use  $\lll$  or  $\ggg$  to locate the beginning of the part you want to erase (point A), then press  $\square$  to pause at that point.
- 3** Press **EDIT** repeatedly to display “A–B Erase?”, then press **SET/ENTER**.
  - Point A (from step 2) is registered and “Erase A\_” appears in the display.
- 4** Use  $\ggg$  and  $\ggg$  to locate the end of the part you want to erase (point B).
- 5** Press **SET/ENTER** to register point B.
  - “Check” appears, then the part you specified plays repeatedly and “Erase A–B?” appears in the display.

#### To adjust points A and B

- Press **EDIT** repeatedly to display “A point” and “B point” alternately. Adjust the selected point by using  $\lll$  or  $\ggg$  in the direction you want to move the point. Each point can be adjusted up to 2 seconds in either direction.
- 6** Press **SET/ENTER** again.
    - The part is erased and “Complete” appears momentarily.

#### Notes

- After part erase, a new track number is automatically assigned to the section starting after point B.
- Point B cannot be positioned before point A.

## Disc or track title erase

This operation lets you erase the title of the disc or the title of tracks on a disc. The title of the disc can only be erased during the stop mode, however, the title of the track can be erased during play or stop mode.

### To erase a disc title

- 1 Press  $\square$  to set this unit to stop mode.
- 2 Press **EDIT** repeatedly to display “Title Erase?”, then press **SET/ENTER**.
  - “Disc Title” and “Erase OK?” appear alternatively in the display.
- 3 Press **SET/ENTER** again.
  - The disc title is erased and “Complete” appears momentarily.

### To erase a track title

- 1 Use  $\lll$  or  $\ggg$  to select the track with the title you want to erase.
- 2 Press **EDIT** repeatedly to display “Title Erase?”, then press **SET/ENTER**.
  - “Track Title” and “Erase OK?” appear alternatively in the display.
- 3 Press **SET/ENTER** again.
  - The track title is erased and “Complete” appears momentarily.

### Notes

- Note that the DISC and TRACK indicators appear in the display when “Title Erase” is displayed to distinguish between the two operations.
- To avoid mistakes when erasing the disc or track names, press **DISPLAY** repeatedly until the title display screen appears so that titles can be confirmed beforehand.

## Move

This function lets you change the position of any track. When you move tracks, all tracks are automatically renumbered.

### Example: Moving track 2 to track number 4

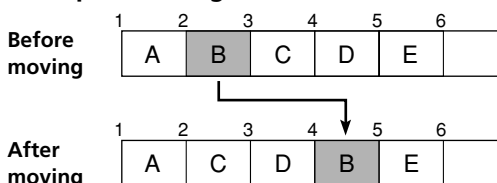

- 1 Use  $\lll$  or  $\ggg$  to select the track you want to move.

- 2 Press **EDIT** repeatedly to display “Move ?”, then press **SET/ENTER**.

- 3 Use  $\lll$  or  $\ggg$  to select the track’s destination (new track number).

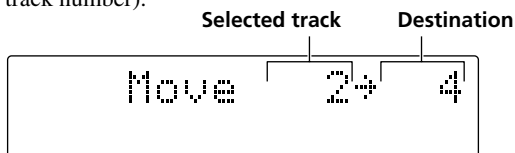

- 4 Press **SET/ENTER**.
  - “Complete” appears momentarily in the display.

## Combine

This function lets you combine two consecutive tracks into one. After you combine the tracks, the total number of tracks decreases by one and the tracks following the combined tracks are renumbered.

### Example: Combining tracks 2 and 3

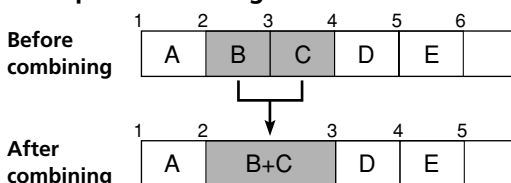

- 1 Press  $\square$  to stop playback.
- 2 Use  $\lll$  or  $\ggg$  to select the second track of the two you want to combine.
- 3 Press **EDIT** repeatedly to display “Combine ?”, then press **SET/ENTER**.
  - “Check” appears momentarily, then the MD recorder plays the 4 seconds before and after the point where the tracks will be connected. “(track number) + (track number) OK?” appears in the display.
- 4 Press **SET/ENTER** again.
  - The tracks are combined and “Complete” appears momentarily.

### Note

- A track recorded in MDLP mode cannot be combined with a track recorded in the non-MDLP mode. (“Impossible” appears in the display.)

## Divide

This function lets you divide one track into two separate tracks by adding a new track number to a specified point in the track.

### Example: Dividing track 3

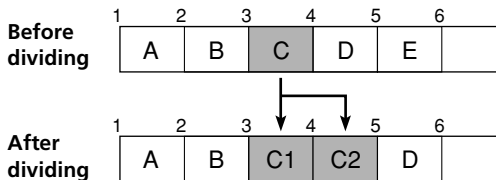

- 1** Play the track you want to divide.
- 2** Use <<< or >>> to locate the point where you want to divide the track, then press **⏸** to pause at that position.
- 3** Press **EDIT** repeatedly to display “Divide?”, then press **SET/ENTER**.
  - “Check” appears momentarily, then “Divide OK?” appears and the MD recorder starts repeating the point where the track will be divided.
- 4** If necessary, use <<< or >>> to adjust the position of the point where the track will be divided.
  - The dividing position can be adjusted up to 2 second (255 steps) in either direction.
- 5** Press **SET/ENTER**.
  - The track is divided and “Complete” appears momentarily.

## Undo

The UNDO function lets you immediately return to the condition before an edit is made (note: you cannot undo an edit once you press any other button).

- 1** Press **□** to stop the MD recorder.
- 2** Press **EDIT** repeatedly to display “Undo \_\_\_\_\*!”, then press **SET/ENTER**.
  - “Undo OK?” appears in the display. To cancel undoing, press **□**.

—\*!: The type of editing you can undo is displayed here.
- 3** Press **SET/ENTER** again to undo.

### Note

- You cannot undo an edit once it has been written to the TOC.

## TOC write

When making a recording, the TOC (Table Of Contents) of the MD is written as soon as recording is finished. When making disc edits or titling, however, the TOC isn’t automatically written unless the disc is ejected. If the unit is accidentally turned off before writing edits or titling to the TOC, it is possible that these changes will not be saved. By using this function, you can ensure that your edits or titles are saved on the disc.

- 1** Press **□** to stop playback.
- 2** Press **EDIT** repeatedly to display “TOC Write?”, then press **SET/ENTER**.
  - “TOC Write OK?” appears.
- 3** Press **SET/ENTER**.
  - “TOC Writing” blinks in the display momentarily.

### Note

- The TOC Write function can only be selected when the TOC indicator is lit in the display.

## FRA check

When edit functions such as “MOVE” and “DIVIDE” are performed, spaces of recordable space may be lost and “TOC Full” may appear in the display to indicate that no more recording can be performed. When this occurs, it may be possible to recover the FRA (Freely Recordable Area) on the disc that was lost during edit functions so that more recording is possible.

- 1** Press **□** to stop playback.
- 2** Press **EDIT** repeatedly to display “FRA Check?”, then press **SET/ENTER**.
  - “FRA Check OK?” appears.
- 3** Press **SET/ENTER**.
  - “Complete” appears momentarily.

This function lets you title recorded MDs and the individual tracks. Titles may consist of uppercase and lowercase letters, numbers, and symbols for a maximum of up to 250 characters for each title.

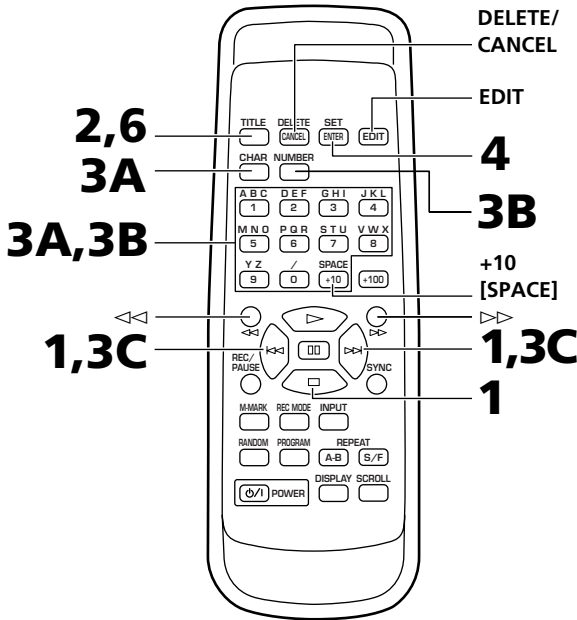

## 1 To title a disc

Press  $\square$  to stop playback.

### To title a track

- ① Press  $\square$  to stop playback.
- ② Use  $\lll$  or  $\ggg$  to select the track you want to title. You can also title during playback, pause, or recording. However, UNDO is not possible in these cases.

## 2 Press **TITLE** to activate the title mode.

- The cursor appears in the display.

## 3 A) To enter letters of the alphabet

- ① Press **CHAR** repeatedly to select between uppercase letters (A, B, C...) and lowercase letters (a, b, c...).
- ② Use the numbers [characters] buttons to select a letter.

### B) To enter numbers

- ① Press **NUMBER**.
- ② Use the numbers [characters] buttons to select a number.

### C) To enter symbols (! # \$ % &...)

Use  $\lll$  or  $\ggg$  to select a symbol. Symbols are between numbers and uppercase letters in the character set.

### Example:

- **Having pressed CHAR in step 3:**  
Press **1 [ABC]** once to select "A".  
Press **1 [ABC]** twice to select "B".
- **Having pressed NUMBER in step 3:**  
Press **1 [ABC]** to select "1".
- **To search symbols quickly:**  
Having pressed **CHAR** and **1 [ABC]** to select uppercase "A", press  $\lll$  to search symbols from the end.

Also, you can use  $\lll$  or  $\ggg$  repeatedly to scroll through the entire character set.

## 4 Press **SET/ENTER** to enter the character.

### Note

- When a number is selected using a number button in step 3, it is not necessary to press **SET/ENTER**.

## 5 Repeat steps 3 and 4 to complete your title.

### To delete a character (ABCD → ABD)

- ① Use  $\lll$  or  $\ggg$  to move the cursor to the position of the character you want to delete.
- ② Press **DELETE/CANCEL**.

### To insert a character (ABCD → ABICD)

- ① Use  $\lll$  or  $\ggg$  to move the cursor to the position where you want to insert the character.
- ② Use **CHAR** or character buttons to select the new character.
- ③ Press **SET/ENTER** to set the character. The character previously in that position automatically moves to the right.

### To insert a space (ABCD → AB\_CD)

- ① Use  $\lll$  or  $\ggg$  to move the cursor to the position where you want to insert the space.
- ② Press **+10 [SPACE]** on the remote control.

### To cancel titling

Press  $\square$ .

## 6 Press **TITLE** to exit the title mode.

- If a title consists of more than 12 characters, it will scroll across the display once and then be displayed in abbreviated form (first 12 characters only).

### To undo TITLE

- ① Press  $\square$  to display the total tracks and total playing time on the disc.
- ② Press **EDIT** repeatedly to display "Undo Title", then press **SET/ENTER**. "Undo OK ?" appears in the display.
- ③ Press **SET/ENTER** again to undo.

## 7 If the TOC indicator is lit, perform the TOC WRITE function.

### To perform the TOC WRITE function

- ① Follow the procedure of "TOC write" on page 20.
- ② Press  $\triangle$  on the front panel. (The MD recorder automatically performs the TOC WRITE function.)

## MD recorder system notes

The recording system in your MD recorder is radically different from those used in cassette and DAT decks and is characterized by the limitations described below. Note, however, that these limitations are inherent to the MD recording system and are not a result of mechanical trouble.

### **“Can’t REC!” is displayed before the maximum recording time has been reached**

Once 255 tracks have been recorded on one MD, “Can’t REC” is displayed regardless of the total recorded time.

### **“TOC Full” is displayed before the maximum number of tracks (255) have been recorded**

During automatic track marking, fluctuations in emphasis within songs may be interpreted as song intervals, increasing the total number of tracks and causing “TOC Full” to be displayed.

### **The remaining recording time does not increase even after erasing numerous short tracks**

Tracks under 12 seconds in length are not counted and so erasing them may not lead to an increase in the recording time.

### **“TOC Reading” is displayed continuously**

The “TOC Reading” display lasts longer than normal when a brand new (blank) disc is inserted.

### **The total recorded time and the remaining time on the MD do not total to the maximum recording time**

- Recording is done in minimum units of 2 seconds each, no matter how short the material.
- This unit displays the length of the largest continuous blank area as the remaining time. Therefore, if there are several separate blank spaces, the remaining time will only display a time equivalent to the largest continuous blank space.

### **Tracks created through editing may exhibit sound dropout during search operations.**

### **Track numbers are not recorded correctly**

Incorrect assignment or recording of track numbers may result when CD tracks are divided into several smaller tracks during digital recording.

### **It is not possible to erase part of a track using the A-B ERASE function**

This unit organizes the audio data in sound groups and clusters. The minimum size of these units may not consist of less than 10 seconds of stereo sound.

### **Limitations when recording over an existing track**

- The correct remaining recording time may not be displayed.
- You may find it impossible to record over a track if that track has been recorded over several times already. If this happens, erase the track using the ERASE function.
- The remaining recording time may be shortened out of proportion to the total recorded time.
- Recording over a track to eliminate noise is not recommended since this may shorten the duration of the track.
- You may find it impossible to label a track while recording over another track.

### **The correct recorded/playing time may not be displayed during playback of MDs recorded in monaural.**

## **SCMS - Serial Copy Management System**

As a digital audio component, this MD recorder conforms with the Serial Copy Management System (SCMS) standards. The Serial Copy Management System restricts copies made by recording digital signals to first-generation copies only. Therefore, an MD recorded through a digital input cannot be used as a source for making another digital recording.



## Display messages

### Can't copy

Digital recording cannot be performed. (See "SCMS - Serial Copy Management System" on page 22.)

### Can't edit!

Edit operations are not possible.

### Can't REC!

Recording is not possible. The loaded disc may be protected or there may not be enough blank space remaining on the disc.

### Can't REC

Recording is not possible. The loaded disc may be damaged.

### DIG in Unlock

No digital signal is being input to the selected digital input jack.

### TMP Over!!

The temperature of the unit has exceeded the normal operating temperature. Turn off the unit and let it cool down. If the unit is installed in a place with little ventilation (such as a built in bookcase), move the unit to another location with better ventilation.

### Disc Full

Recording is not possible because there is no blank space remaining on the disc.

### Title Full!

Additional characters cannot be input for the current title because the maximum number of characters for a single title (250) has already been input.

### UTOOC W Error

Error occurred when writing to the UTOC.

### Not Audio

The inserted disc is not an audio MD.

### Tr Protected

The selected track cannot be edited because it is protected.

### TOC Full

The disc area allotted for TOC data has become full and further editing is not possible.

### UTOOC Err L0~4

Problem involving UTOC data.

### TOC Writing

The TOC data is being written to the disc. Do not move the unit or pull out the mains lead. If you do, recorded material may not be saved normally.

### TOC Reading

The unit is reading the TOC data.

### Protected

The record protection on the inserted MD is set to "protect".

### PlayBack MD

The inserted MD is a designed for playback only (you cannot record on this disc).

### Monitor Out

The monitor out function is active. The audio signal input to the selected input terminals is output from this unit's output terminals.

### No Track

Blank disc is played or searched.

## Troubleshooting

If your MD recorder fails to operate normally, check the following table. It lists common operating errors and simple measures which you can take to correct the problem. If it cannot be corrected, or the symptom is not listed, disconnect the recorder's power cord and contact your authorized YAMAHA dealer or service center for help.

SYMPTOM	CAUSE	REMEDY
<b>The unit does not respond to operations.</b>	MD is dirty or damaged.	Replace the current disc with a new one.
	MD is damaged ("UTOC Err L0~4" appears in the display).	
<b>The unit does not work normally.</b>	There is an influence of strong external noise (lightning, excessive static electricity, etc.) or a misoperation was performed while using this unit.	Turn the power off and disconnect the AC power from the AC outlet. After about 30 seconds have passed, connect the power and try again.
<b>Playback is not possible.</b>	Moisture is on the laser pickup.	Leave the unit switched ON and wait 20 to 30 minutes for the moisture to evaporate before trying to play a disc.
	The power is OFF.	Press STANDBY/ON (POWER on the remote control) to turn the power on.
	The disc has been loaded incorrectly.	Reload the disc with the label side facing up, and the arrow pointing toward the disc insertion slot.
	An unrecorded (blank) MD was loaded ("Blank Disc" appears in the display).	Insert a recorded MD.
<b>Recording is not possible.</b>	The disc is write protected ("Protected" appears in the display).	Slide the write-protect tab to the closed position.
	A pre-mastered MD is loaded ("PlayBack MD" appears in the display).	Load a recordable MD.
	The source is not connected correctly.	Check all connections again.
	The input setting is incorrect.	Press INPUT repeatedly to select the correct input jacks.
	The recording level is too low.	Turn REC LEVEL to adjust the recording level.
	The digital output level of the digital source is too low.	Set the digital output level of the digital source to "MAX".
	There is not enough blank space left on the MD.	Load a recordable MD with fewer recorded tracks, or erase unnecessary tracks from the current MD.
	If the power cord was unplugged or there was a power outage during recording, that recording may be lost.	If recording was interrupted, try recording again starting from the beginning.
<b>The MD cannot be removed when partially inserted.</b>	The carriage lock function has activated.	Insert the MD completely, then press  to eject it.
<b>Excessive noise.</b>	The unit is too close to the television or other component.	Place the unit farther away from the television or other component.
<b>The remote control does not operate.</b>	The batteries are exhausted.	Replace the batteries.
	The remote control transmitter is operated from an incorrect distance or angle.	Operate the remote from less than 6 meters (about 20 feet) and within 30° on either side of the sensor.
	The remote control sensor is located in strong direct light.	Place the unit away from the strong light.

# Specifications

## Digital audio system

System .....	MiniDisc digital audio system
Laser .....	Semiconductor laser
Laser diode properties	
Material .....	GaAIs
Wavelength .....	785 nm
Pulse time	
Read mode .....	0.6 mW Continuous
Write mode .....	Accessible emission level 2.6 mW 0.5S
	min cycle 1.5S
	Repetition
Record/Playback time .....	Max. 80 minutes (Stereo)
	261 minutes (ATRAC3-LP2)
	323 minutes (ATRAC3-LP4)
Sampling frequency .....	44.1 kHz
	(32 kHz and 48 kHz signals converted to 44.1 kHz for recording)
Frequency response .....	5 – 20,000 Hz ±0.5 dB
Signal-to-Noise ratio .....	99 dB
Digital rec level .....	Min. – +12 dB

## Inputs

LINE IN (REC)	
Type .....	Pin jack
Standard input level (50 k-ohms) .....	300 mV
DIGITAL IN (OPTICAL) (2)	
Type .....	Square optical connector jack

## Outputs

LINE OUT (REC)	
Type .....	Pin jack
Standard output level (1 kHz, 0 dB) .....	2.0 ± 0.5 Vrms
DIGITAL OUT (OPTICAL)	
Type .....	Square optical connector jack

## General

Power supplies	
[U.K. and Europe models] .....	230 V, 50 Hz
[General model] .....	110/120/220/240 V, 50/60 Hz
Power consumption .....	12 W
Power consumption (standby mode)	
[U.K. and Europe models] .....	7.5 W
[General model] .....	7.6 W
Dimensions (W x H x D) .....	217 x 88 x 297 mm
	(8-9/16" x 3-7/16" x 11-11/16")
Weight .....	2.6 kg (5 lbs. 12 oz.)

Specifications subject to change without notice.

US and foreign patents licensed from Dolby Laboratories Licensing Corporation.

**CAUTION**

Use of controls or adjustments or performance of procedures other than those specified herein may result in hazardous radiation exposure.

**ATTENTION**

L'emploi de commandes, de réglages ou un choix de procédures différents des spécifications de cette brochure peut entraîner une exposition à d'éventuelles radiations pouvant être dangereuses.

**ACHTUNG**

Die Verwendung von Bedienungselementen oder Einstellungen oder die Durchführung von Bedienungsvorgängen, die nicht in dieser Anleitung aufgeführt sind, kann zu einem Kontakt mit gefährlichen Laserstrahlen führen.

**OBSERVERA**

Användning av kontroller och justeringar eller genomförande av procedurer andra än de som specificeras i denna bok kan resultera i att du utsätter dig för farlig strålning.

**ATTENZIONE**

Uso di controlli o regolazioni o procedure non specificamente descritte può causare l'esposizione a radiazioni di livello pericoloso.

**PRECAUCIÓN**

El uso de los controles o los procedimientos de ajuste o utilización diferentes de los especificados en este manual pueden causar una exposición peligrosa a la radiación.

**VOORZICHTIG**

Gebruik van bedieningsorganen of instellingen, of uitvoeren van handelingen anders dan staan beschreven in deze handleiding kunnen leiden tot blootstelling aan gevaarlijke stralen.

**VARO!**

**AVATTAESSA JA SUOJALUKITUS  
OHITETTAESSA OLET ALTTIINA  
NÄKYMÄTTÖMÄLLE LASERSÄTEILYLLE. ÄLÄ  
KATSO SÄTEESEEN.**

**WARNING!**

**OSYNLIG LASERSTRÅLNING NÄR DENNA DEL  
ÄR ÖPPNAD OCH SPÄRREN ÄR URKOPPLAD.  
BETRAKTA EJ STRÅLEN.**

**CLASS 1 LASER PRODUCT  
LASER KLASSE 1 PRODUKT  
LJOKAN 1 LASERLAITE  
KLASS 1 LASER APPARAT**

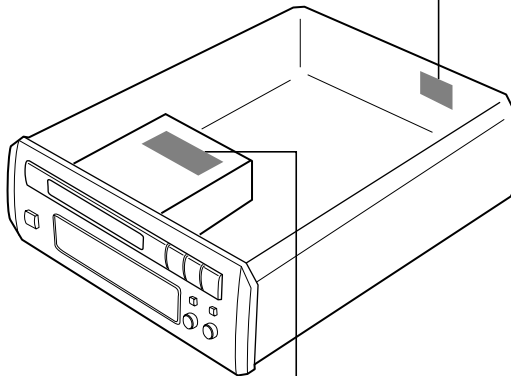

CAUTION - VISIBLE AND / OR INVISIBLE LASER RADIATION WHEN OPEN. AVOID EXPOSURE TO BEAM.
VARNING - SYNLIG OCH / ELLER OSYNLIG LASERSTRÅLNING NÄR DENNA DEL ÄR ÖPPNAD. STRÅLEN ÄR FARLIG.
VARO! AVATTAESSA OLET ALTTIINA NÄKYMÄLLE JA / TAI NÄKYMÄTTÖMÄLLE LASERSÄTEILYLLE. ÄLÄ KATSO SÄTEESEEN.
VARNING - SYNLIG OCH / ELLER OSYNLIG LASERSTRÅLNING NÄR DENNA DEL ÄR ÖPPNAD. BETRAKTA EJ STRÅLEN.
VORSICHT! SICHTBARE UND / ODER UNSICHTBARE LASERSTRÄHLUNG WENN ABDECKUNG GEÖFFNET. NICHT DEM STRAHL AUSSETZEN.